



Rewarding Learning

ADVANCED SUBSIDIARY (AS)
General Certificate of Education
2019

Uimhir Lárionaid

--	--	--	--	--

Uimhir Iarrthóra

--	--	--	--

Fisic

Aonad Measúnaithe AS 3A

ag measúnú

Teicnící Praiticiúla
agus Anailísiú Sonraí



SPH31

[SPH31]

DÉ HAOINE 3 BEALTAINÉ, MAIDIN

AM

1 uair chloig.

TREOIR D'IARRTHÓIRÍ

Scríobh d'Uimhir Lárionaid agus d'Uimhir Iarrthóra sna spásanna chuige sin ag barr an leathanaigh seo.

Freagair **gach** ceist sa leabhrán seo. Ní mór obair gharbh agus ríomhanna a dhéanamh sa leabhrán seo fosta. Seachas san áit a dtugtar treoir, **ná** cuir síos ar an fhearas nó ar ghnásanna turgnamhacha. Inseoidh an Múinteoir/Maoirseoir duit an t-ord nach mór duit na ceisteanna a fhreagairt. Ní mór aon uair an chloig a chaitheamh ar cheithre thástáil thurgnamhacha ghairide.

I ndiaidh 12 nóiméad ní mór duit stopadh de bheith ag úsáid an fhearais sa dóigh gur féidir é a athchóiriú don chéad iarrthóir eile. Ar 14 nóiméad tabharfar treoir duit bogadh go dtí an stáisiún don chéad cheist eile. Ag deireadh na tástála cuirfear tréimhse 4 nóiméad ar fáil duit le do fhreagra ar cheist ar bith a chomhlánú, ach ní bheidh fáil agat ar an fhearas le linn an ama seo.

EOLAS D'IARRTHÓIRÍ

Is é 40 an marc iomlán don scrúdpháipéar seo.

Léiríonn figiúirí idir lúibíní atá priontáilte ar thaobh na láimhe deise de leathanaigh na marcanna atá ag dul do gach ceist nó do gach cuid de cheist.

Tá cead agat áireamhán leictreonach a úsáid.

Don Scrúdaitheoir
amháin

Uimhir Ceiste	Marcanna	Athmharc
1		
2		
3		
4		

Marc Iomlán		
-------------	--	--

Scrúdaitheoir Amháin	
Marcanna	Athmharc

1 Aimsigh an fuinneamh atá stóráilte i lingeán rite.

Tugann **Cothromóid 1.1** an ghaolmhaireacht idir an fuinneamh straidhne E atá stóráilte i lingeán rite agus síneadh x an lingeáin nuair a chuirtear fórsa F i bhfeidhm.

$$E = \frac{1}{2}Fx \quad \text{Cothromóid 1.1}$$

(a) Bain úsáid as an fhearas atá curtha ar fáil le léamha cuí a ghlacadh óna dtig leat an fuinneamh atá stóráilte a aimsiú nuair a chrochtar mais 200g agus mais 400g ón lingeán.

(i) Tomhais fad tosaigh an lingeáin.

Fad tosaigh an lingeáin = _____ cm [1]

(ii) Croch an mhais 200g ón lingeán. Comhlánaigh na colúin atá fágtha i **dTábla 1.1**. Déan an próiseas arís leis an mhais 400g.

Tábla 1.1

Mais / g	Fórsa / N	Fad nua an lingeáin / cm	Síneadh / cm
200			
400			

[4]

(iii) Luaigh luach na neamhchinnteachta i bhfad thomhaiste an lingeáin. Mínigh foinse na neamhchinnteachta seo.

Neamhchinnteacht = _____ cm

 _____ [1]

(iv) Luaigh an neamhchinnteacht i síneadh an lingeáin.

Neamhchinnteacht = _____ cm [1]

- (b) (i) Ríomh an fuinneamh atá stóráilte sa lingeán nuair a chrochtar gach mais.

Fuinneamh atá stóráilte le mais 200 g crochta = _____ J

Fuinneamh atá stóráilte le mais 400 g crochta = _____ J
[2]

- (ii) Baineann dalta úsáid as **Cothromóid 1.1** le tuar a dhéanamh go bhfuil an fuinneamh atá stóráilte i gcomhréir leis an fhórsa atá curtha i bhfeidhm. Ba chóir go dtaispeánfadh do thorthaí nach bhfuil an cás amhlaidh.

Mínigh cad chuige nach bhfuil an tuar seo ceart.

[1]

Scrúdaitheoir Amháin	
Marcanna	Athmharc

2 Aimsigh friotaíocht fhriotóirí anaithnide.

Tá dhá líonra fhriotóirí curtha ar fáil duit. Tá trí fhriotóir i ngach líonra, dhá fhriotóir chothroma, lipéadaithe **A**, agus an fhriotóir eile, lipéadaithe **B**. Tá soláthar cumhachta, voltmhéadar agus miollaimpmhéadar curtha ar fáil duit fosta.

- (a) Cuir ciorcad cuí le chéile óna dtig leat friotaíocht gach líonra a aimsiú. Glac léamha cuí agus déan iad a thaifeadh i **dTábla 2.1**.

Ní gá duit léamha a athdhéanamh sa turgnamh seo.

Ríomh friotaíocht gach líonra agus taifead na luachanna i **dTábla 2.1**.

Tábla 2.1

Líonra			
Na trí fhriotóir uilig i sraithcheangal			
An dá fhriotóir A i dtreocheangal ceangailte i sraithcheangal le B			

[7]

- (b) Ríomh friotaíocht fhriotóir **A** agus friotaíocht fhriotóir **B**.

Friotóir **A** = _____ Ω

Friotóir **B** = _____ Ω

[3]

Scrúdaitheoir Amháin	
Marcanna	Athmharc

LEATHANACH BÁN

(Leanann ceisteanna ar an chéad leathanach eile)

3 Aimsigh mais chórais ascalaithe.

Tá dhá chóras ascalaithe, a bhfuil maiseanna difriúla acu, curtha ar fáil duit. Tá córas 1 ina shuí go ceartingearach ar an deasc mar atá taispeánta i **bhFíor 3.1a**. Nuair a dhéantar an córas a dhíláithriú sa bheagán tarlóidh ascaluithe dó.

Is é is tréimhse ascalaithe ann ná an t-am a thógann sé ar an chóras ascalú ó A go B agus ar ais go dtí A arís, mar atá taispeánta i **bhFíor 3.1b**.

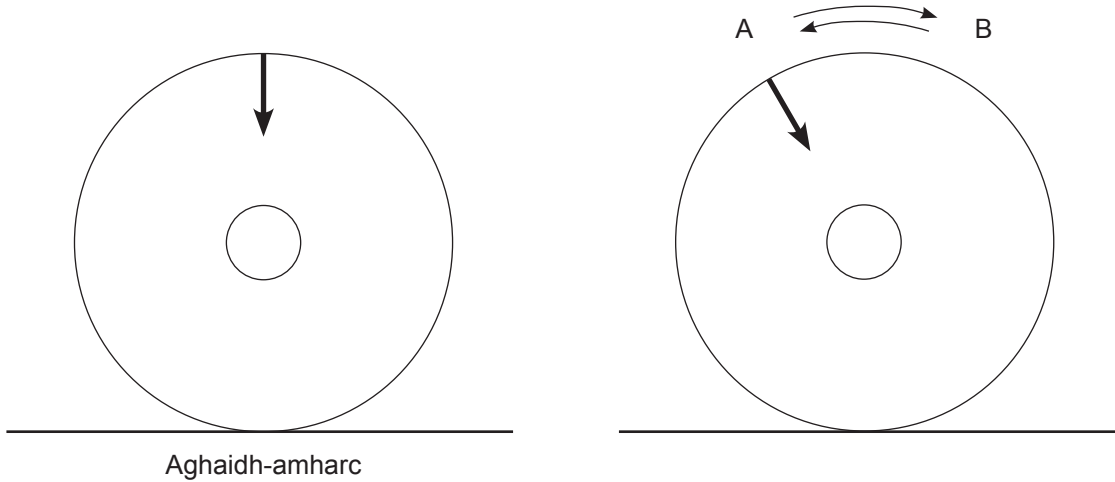

Fíor 3.1a

Fíor 3.1b

Tá mais m gach chórais taifeadta i **dTábla 3.1**.

- (a) Déan córas 1 a dhíláithriú sa bheagán trí do mhéar a chur os cionn na saighde atá tarraingthe ar an chóras agus é a rothlú sa bheagán go dtí suíomh A mar atá taispeánta i **bhFíor 3.1b**. Scaoil an córas agus lig dó ascalú.

Tóg léamha cuí óna dtig leat luach cruinn iontaofa a ríomh do thréimhse ascalaithe T an chórais. Taifead do léamha uilig i **dTábla 3.1**.

Déan an gnás seo arís do chóras 2.

Tábla 3.1

Córas	m / g	Tréimhse Ascalaithe T / s
1	25	
2	45	

[6]

Scrúdaitheoir Amháin	Marcanna Athmharc

(b) Tá T i gcomhréir inbhéartach le \sqrt{m} . Bain úsáid as do thorthaí le luach a fháil do mhais córas eile a bhfuil tréimhse ascalaithe de 0.30 s aige.

m = _____ g

[4]

Scrúdaitheoir Amháin	
Marcanna	Athmharc

4 Aimsigh an chomhéifeacht athraonta.

Tá bloc gloine agus scáthán plánach curtha ar fáil duit. Lean na treoracha go cúramach le léaráid gathanna a thógáil óna nglacfaidh tú tomhais le luach a ríomh do chomhéifeacht athraonta an bhloic.

(a) (i) Ullmhúchán

Agus **Fíor 4.2** ar leathanach 9 i gceist, cuir aghaidh an bhloic gloine, lipéadaithe F, ar an leathanach leis an chiumhais fhada ar an líne atá lipéadaithe ‘ciumhais uachtair an bhloic’ agus coirnéal an bhloic gloine sa tsuíomh atá lipéadaithe.

Tarraing línte thart ar an bhloc gloine.

Tarraing líne atá comhthreomhar leis an bhloc gloine agus 5.0 cm ar shiúl ó chiumhais íochtair an bhloic gloine. Cuir an scáthán ar an líne seo mar atá léirithe i **bhFíor 4.1**. [1]

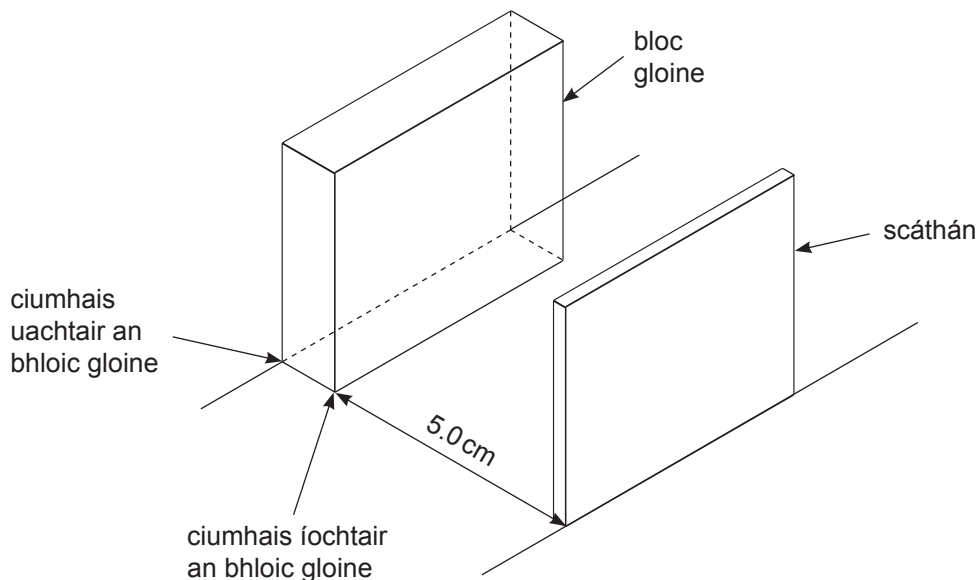

Fíor 4.1

(ii) Tógáil léaráid gathanna

Soilsigh ga solais feadh na líne atá lipéadaithe ‘ga ionsaitheach’ i **bhFíor 4.2**. Marcáil pointí cuí a ligfidh duit conair an tsolais a tharraingt de réir mar a théann sé tríd an bhloc, a imíonn sé ón bhloc, a fhrithchaitheann sé ón scáthán agus a théann sé tríd an bhloc arís, ag imeacht ón bhloc ón chiumhais chéanna a ndeachaigh sé isteach ann.

Bain an bloc agus an scáthán ar shiúl agus tarraing conair iomlán an gha. [3]

Scrúdaitheoir Amháin	
Marcanna	Athmharc

Scrúdaitheoir Amháin	
Marcanna	Athmharc

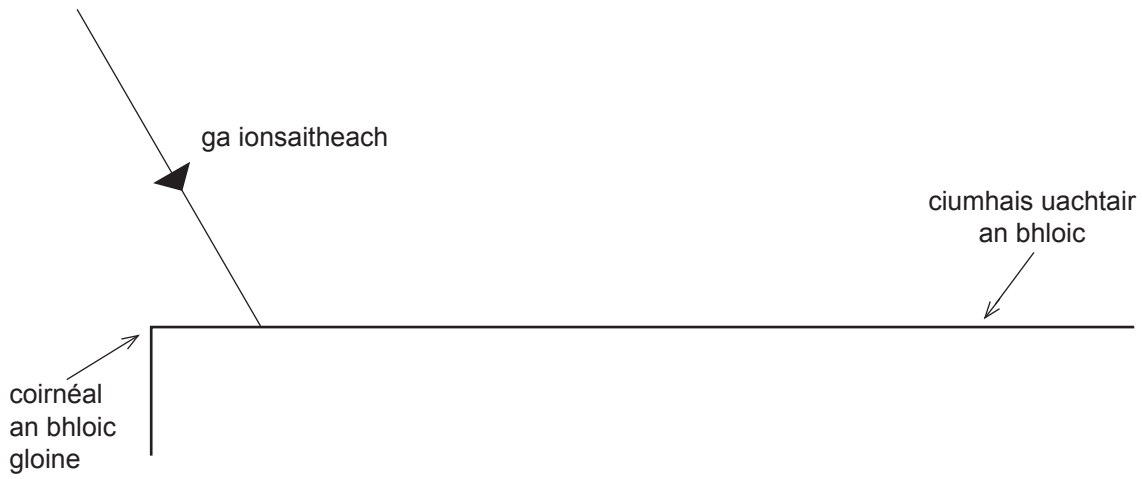

Fíor 4.2

(iii) Tomhais

Tomhais iad seo a leanas:

Fad chonair an gha solais taobh istigh den bhloc gloine de réir mar a théann sé ón chiumhais uachtair go dtí an chiumhais íochtair. Seo X.

$$X = \text{_____ cm}$$

Fad chonair an gha solais idir an bloc gloine agus an scáthán. Seo Y.

$$Y = \text{_____ cm}$$

An fad slí idir an pointe ag a dtéann an ga solais isteach sa bhloc gloine agus an pointe ag a n-imíonn sé ón bhloc gloine feadh na ciumhaise uachtair. Seo A.

$$A = \text{_____ cm}$$

An fad slí idir an pointe ag a n-imíonn an ga solais ón bhloc gloine agus an pointe ag a dtéann sé isteach sa bhloc gloine feadh na ciumhaise íochtair. Seo B.

$$B = \text{_____ cm} \quad [4]$$

- (b)** Is féidir na tomhais a taifeadadh in **(a)(iii)** a úsáid leis an chomhéifeacht athraonta n a ríomh le **Cothromóid 4.1**.

$$n = \frac{BX}{Y(A-B)} \quad \text{Cothromóid 4.1}$$

Bain úsáid as do thomhais le luach a ríomh don chomhéifeacht athraonta.

$$\text{Comhéifeacht athraonta} = \text{_____} \quad [2]$$

Scrúdaitheoir Amháin	
Marcanna	Athmharc

SEO DEIREADH AN SCRÚDPHÁIPÉIR

Cuireadh isteach ar chead chun an t-ábhar cóipchirt uile a atáirgeadh.
I gcásanna áirithe is féidir nár éirigh le CCEA teagmháil a dhéanamh le húinéirí cóipchirt agus beidh sé sásta na hadmhálacha sin a fágadh ar lár a chur ina gceart amach anseo ach é a chur ar an eolas.



Rewarding Learning

**ADVANCED SUBSIDIARY (AS)
General Certificate of Education
2019**

Physics

Assessment Unit AS 3A

Practical Techniques and Data Analysis

**[SPH31]
FRIDAY 3 MAY**

APPARATUS AND MATERIALS LIST

PHYSICS UNIT 3 (AS 3A)
APPARATUS AND MATERIALS REQUIRED FOR PRACTICAL ASSESSMENT

CONFIDENTIAL

This document gives preliminary information on the apparatus and materials required for the AS Practical Assessment.

Information about the apparatus and materials required for this assessment must NOT be communicated to students. If apparatus/materials have their serial code and/or manufacturer specified then it is essential that centres use this exact apparatus/material.

On receipt of this APPARATUS AND MATERIALS LIST, centres must contact Gavin Gray, ggray@ccea.org.uk immediately if they have difficulty in sourcing the specified apparatus or materials.

Teachers will be given detailed instructions for setting up the experiment in the *Confidential Instructions for Physics (Advanced Subsidiary) Practical Test*, to which they will have confidential access from April 2019.

Teachers will have confidential access to a copy of the experimental test two working days (48 hours) before the start of the assessment.

The AS 3 Practical Techniques Assessment is a test of practical skills consisting of 4 short experimental tests (40 marks). The duration of the assessment is 1 hour.

The apparatus in the following list will allow for **one experiment** to be set up for the practical test which makes up questions 1–4. In other words, each set of apparatus (as listed on **pages 4 and 5**) will accommodate four candidates when doing the circus of experiments.

The apparatus can be used for alternative sessions according to the following schedule:

3 May 2019 Physics AS 3A (SPH31)

(Main Session) **9.15 am–10.15 am**

(First Alternative) **10.30 am–11.30 am**

(Second Alternative) **11.45 am–12.45 pm**

(Third Alternative) **1.15 pm–2.15 pm**

(Fourth Alternative) **2.30 pm–3.30 pm**

One set of apparatus for AS 3A (SPH31) will therefore be sufficient for twenty candidates on **3 May** if the Main Session and all four alternatives are used. A laboratory may contain one, two, three or more sets of apparatus. This means that four, eight, twelve or more candidates can be accommodated in the same session. **To maintain the confidentiality of details of the practical tests, candidates entered for any of the alternative sessions must be segregated within the centre so that there can be no communication with candidates who have taken an earlier test in any centre.**

IMPORTANT NOTICE

Centres are urged to order items needed for the Physics Practical Tests from the suppliers as soon as possible.

Question 1

- Extension (disposable) spring unextended length 20 mm
- 100 g mass holder × 2
- 100 g slotted mass × 4
- Half metre rule
- Retort stand, boss head and clamp
- Labels

Question 2

- 22 Ω resistor × 4
- 15 Ω resistor × 2
- Milliammeter (range 0–200 mA reading to 0.1 mA)
- Voltmeter (range 0–20V to 0.01V)
- Connecting wires with fitted plug × 5
- Crocodile clips × 2
- 4.5 V d.c. supply (batteries or power pack)
- Box or similar to conceal power supply
- Masking tape
- Labels

Question 3

- Single layer DVD or CD ROM × 4
- 10 g mass (diameter approx. 33 mm) × 2
- 20 g mass (diameter approx. 33 mm) × 2
- Stopclock
- Double sided foam sticky pads, e.g. Sellotape sticky fixers × 6
- Labels/marker suitable for writing on DVD

Question 4

- Ray box and suitable power supply
- Single slit
- Mirror and holder
- 30 cm ruler
- Rectangular glass block (NB: a block with a white face is not suitable for this experiment)
- Sticky label



Rewarding Learning

**ADVANCED SUBSIDIARY (AS)
General Certificate of Education
2019**

Physics

Assessment Unit AS 3A

Practical Techniques and Data Analysis

**[SPH31]
FRIDAY 3 MAY**

**CONFIDENTIAL
INSTRUCTIONS**

1 Confidential Instructions

These instructions will give detailed guidance on setting up and testing the apparatus and materials to be used. **Again, information contained within the Confidential Instructions must not be relayed to candidates under any circumstances.** If at this point, centres find that the testing process produces results different to those specified in the Confidential Instructions, they must contact the CCEA Science Subject Officer (ggray@ccea.org.uk) immediately.

2 Final Apparatus Testing

The practical assessment question paper will be made available to the Head of Physics **two** working days before the timetabled starting time so that teachers and technicians can carry out a final test on the experiments. If on checking the apparatus gives unexpected results, the CCEA Physics Subject Officer should be contacted immediately (ggray@ccea.org.uk). If the problem cannot be resolved, then the centre must e-mail the CCEA Physics Subject Officer stating the centre name and number, the specific nature of the problem and the range of anomalous results produced. CCEA will respond by acknowledging receipt of the e-mail. If you do not receive a response within 24 hours, please contact the CCEA Physics Subject Officer by telephone (028 90261200 Ext 2270) to confirm that CCEA has received your e-mail.

3 Practical Assessment AS 3A

The AS 3A Practical Techniques Assessment is a test of practical skills comprised of 4 short experimental tests. The duration of the assessment is 1 hour. Some of this time will be set aside for supervisors to re-set the apparatus ready for the next candidates. The assessment should be run as a circus of experiments with candidates moving to the next experiment at the designated time. The assessment should be timed as follows:

Questions	Time
Q1 (Short practical test)	12 minutes
Changeover and practical write-up	2 minutes
Q2 (Short practical test)	12 minutes
Changeover and practical write-up	2 minutes
Q3 (Short practical test)	12 minutes
Changeover and practical write-up	2 minutes
Q4 (Short practical test)	12 minutes
Changeover and practical write-up	2 minutes
End of test write-up	4 minutes

At the end of each 12 minute period, candidates must stop using the apparatus. During each 2 minute changeover period candidates may write up anything they have not completed however they will not have access to the apparatus.

At the end of the test a 4 minute period is provided for candidates to complete their answer to any question, however they will not have access to the apparatus.

4 After the Practical Assessments

When the individual exam sessions have finished, please return the AS 3A practical scripts together with the corresponding advice notes to the examinations officer (EO). We will collect these by the day after the examination. If we don't, please contact us immediately to arrange another time for collection.

Where the centre finds that a candidate may have been disadvantaged because the apparatus did not function as intended, the supervising teachers should make a report to the EO. The EO will forward the confidential report on the issue and the candidates affected to the centre support section at CCEA for special consideration. Candidates should be identified by their examination number.

IMPORTANT NOTICE

Centres are urged to order items needed for the Physics Practical Tests from the suppliers as soon as possible.

Question 1

Requirements

- Extension (disposable) spring unextended length 20 mm
- 100 g mass holder × 2
- 100 g slotted mass × 4
- Half metre rule
- Retort stand, boss head & clamp
- Labels

Preparation

Connect the boss head and clamp to the retort stand.

Before the examination

Suspend the unextended spring from the clamp.

Place one 100 g mass onto a 100 g mass hanger, label this '200g'.

Place three 100 g masses onto the other mass hanger, label this '400g'.

Set these beside the retort stand.

Set the half metre rule close to the retort stand.

Action at changeover

Return the apparatus to the original arrangement on the bench.

Question 2

Requirements

- $22\ \Omega$ resistor \times 4
- $15\ \Omega$ resistor \times 2
- Milliammeter (range 0–200 mA reading to 0.1 mA)
- Voltmeter (range 0–20V to 0.01V)
- Connecting wires with fitted plug \times 5
- Crocodile clips \times 2
- 4.5V d.c. supply (batteries or power pack)
- Box or similar to conceal power supply
- Masking tape
- Labels

Preparation

Use the masking tape to conceal the markings on all the resistors. Label the $22\ \Omega$ resistors 'A' and the $15\ \Omega$ resistors 'B'.

Connect two $22\ \Omega$ resistors and a $15\ \Omega$ resistor in series.

Connect two $22\ \Omega$ resistors in parallel with each other and put these in series with a $15\ \Omega$ resistor.

Conceal the power supply and leave the two end terminals exposed with leads attached.

Label the concealed box 'power supply'.

Set the milliammeter to the 200 mA setting and tape the dial in place so that it cannot be moved by the candidate.

Before the examination

Leave all the equipment on the desk – both resistor networks, the concealed power supply, milliammeter, voltmeter and the remaining three connecting wires and crocodile clips.

Action at changeover

Disconnect any circuit, returning the apparatus to the original arrangement.

Question 3

Requirements

- Single layer DVD or CD ROM × 4
- 10g mass (diameter approx. 33mm) × 2
- 20g mass (diameter approx. 33mm) × 2
- Stopclock
- Double sided foam sticky pads, e.g. Sellotape sticky fixers × 6
- Labels/marker suitable for writing on DVD

Preparation

Use the double sided foam sticky pads to stick one of the 10g masses to the DVD/CD as shown in **Fig 3.1**. Stick another 10g mass directly on top of the first and then a second DVD/CD on top. Label this 'System 1: $m = 25g$ '. The arrangement should sit as shown in **Fig 3.1**.

Repeat with the other 2 DVD/CDs, this time with two 20g masses stuck in between. Label this 'System 2: $m = 45g$ '.

Draw an arrow pointing vertically downwards when the DVD/CD sits on the bench as shown in **Fig 3.2**.

When displaced slightly the system should oscillate in excess of 10 oscillations. The period of oscillation of System 2 should be less than System 1.

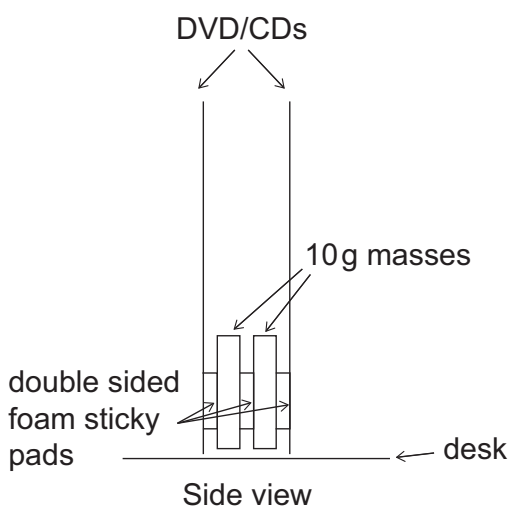

Fig. 3.1

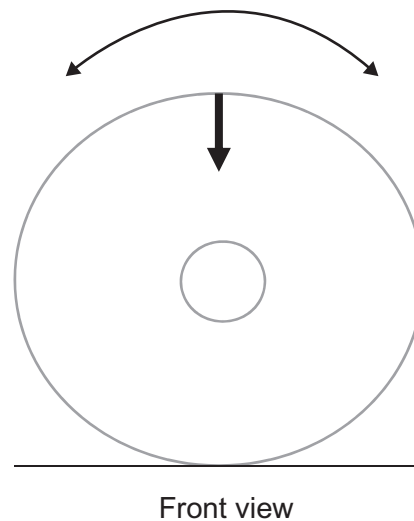

Fig. 3.2

Before the examination

Set system 1 upright on the desk. Leave the other on the desk close by with the stopclock.

Action at changeover

Return the apparatus to the original arrangement.

Question 4

Requirements

- Raybox and suitable power supply
- Single slit
- Mirror and holder
- 30 cm ruler
- Rectangular glass block (NB: A block with a white face is not suitable for this experiment)
- Sticky label

Preparation

Place a sticky label on the long narrow face of the block and label it F.

To ensure the complete path of the ray is visible, it is best to place the apparatus for Question 4 in a dimly lit area.

Before the examination

Connect the power pack to the raybox and insert the single slit into the raybox. Set all of the apparatus on the desk.

Action at changeover

Return the apparatus to the original arrangement.

